

Technical details

Connection	G1/2
Nominal size	14 mm
Temperature range	-10°C ... +70°C
Medium	Filtered, oil-free and dried compressed air according to ISO 8573-1:2010, Class 7:2:4, instrument air, free of aggressive additives. Differing the pressure dew point must be at least 10°C below lowest occurring ambient temperature.
Materials	Body: Al (anodized), seals: NBR and POM, inner parts: Al, brass, stainless steel
	Valves in accordance with 2014/34/EU (ATEX) available. (Chapter 13)

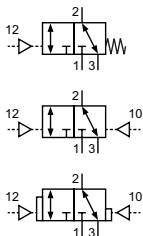

Pneumatically operated spool valve. The valve switches upon pressurization of the pilot port.

3/2-way valves

P-12-311
3/2-way, single pilot, mechanical spring return

P-12-320
3/2-way, double pilot

P-12-322
3/2-way, double pilot, one side dominant

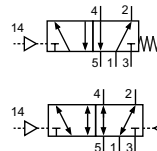
5/2- and 5/3-way valves

P-12-511
5/2-way, single pilot, mechanical spring return

P-12-520
5/2-way, double pilot

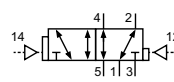

P-12-522
5/2-way, double pilot, one side dominant

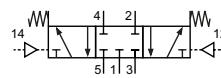

P-12-530
5/3-way, center position closed

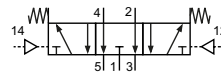

P-12-533
5/3-way, center position exhausted

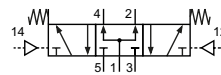

P-12-534
5/3-way, center position pressurized

Technical data

Model-no.:	P-12-311	P-12-320	P-12-322			
Operating pressure (bar)	1 ... 10	0 ... 10	0 ... 10			
Pilot pressure (bar)	2 ... 10	1 ... 10	1 ... 10			
Flow rate (NI/min)	3300	3300	3300			
Weight (kg)	0.830	0.855	0.855			

Model-no.:	P-12-511	P-12-520	P-12-522	P-12-530	P-12-533	P-12-534
Operating pressure (bar)	0 ... 10	0 ... 10	0 ... 10	0 ... 10	0 ... 10	0 ... 10
Pilot pressure (bar)	2 ... 10	1 ... 10	1 ... 10	3 ... 10	3 ... 10	3 ... 10
Flow rate (NI/min)	3300	3300	3300	3300	3300	3300
Weight (kg)	1.065	1.080	1.080	1.080	1.080	1.080

Series P-12

Dimensions

P-12-311, P-12-320

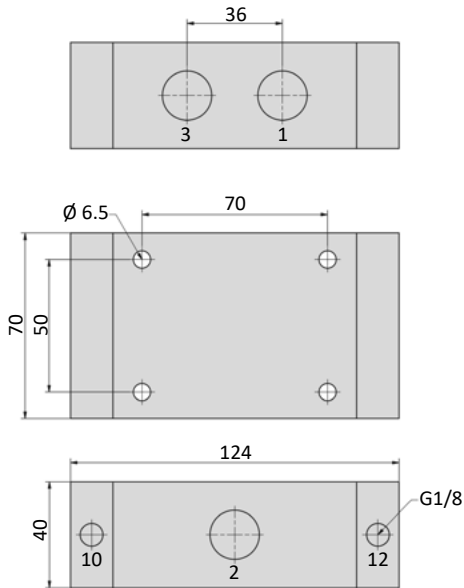

P-12-322

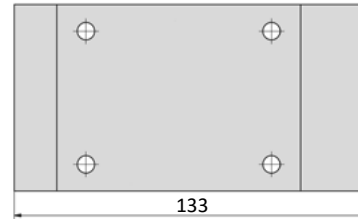

P-12-511, P-12-520, P-12-53x

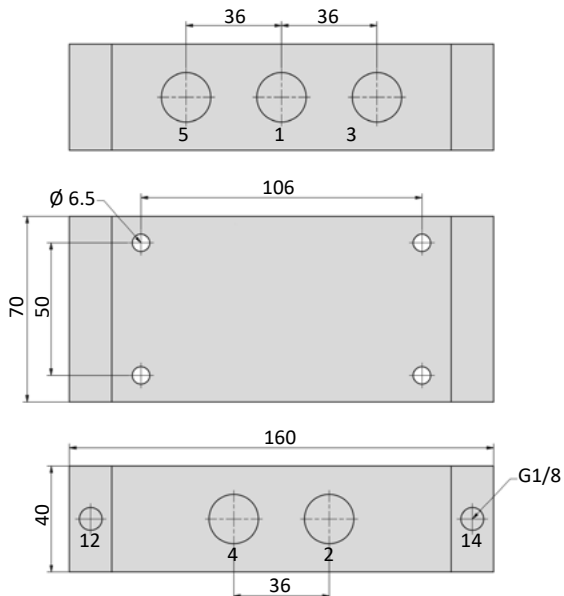

P-12-522

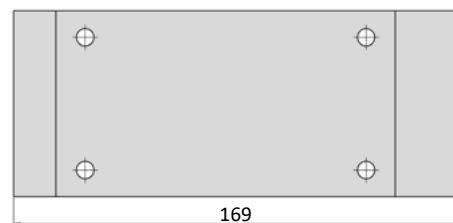

- 1 = pressure inlet
 - 2,4 = outlets
 - 3,5 = exhausts
 - 10,12,14 = pilot ports
- Pilot ports can be repositioned by 180°.